

1	General Arrangement
1a	G.A. parts
1b	Pinion
1c	G.A. brackets
2	Fundation
3	Column
3a	Column parts
3b	Column parts
4	Folding Arm
4a	Folding arm parts
5	Beam
5a	Beam parts
5b	Beam parts
6	Extendable beam
6a	Ext. beam parts
7	Cylinders

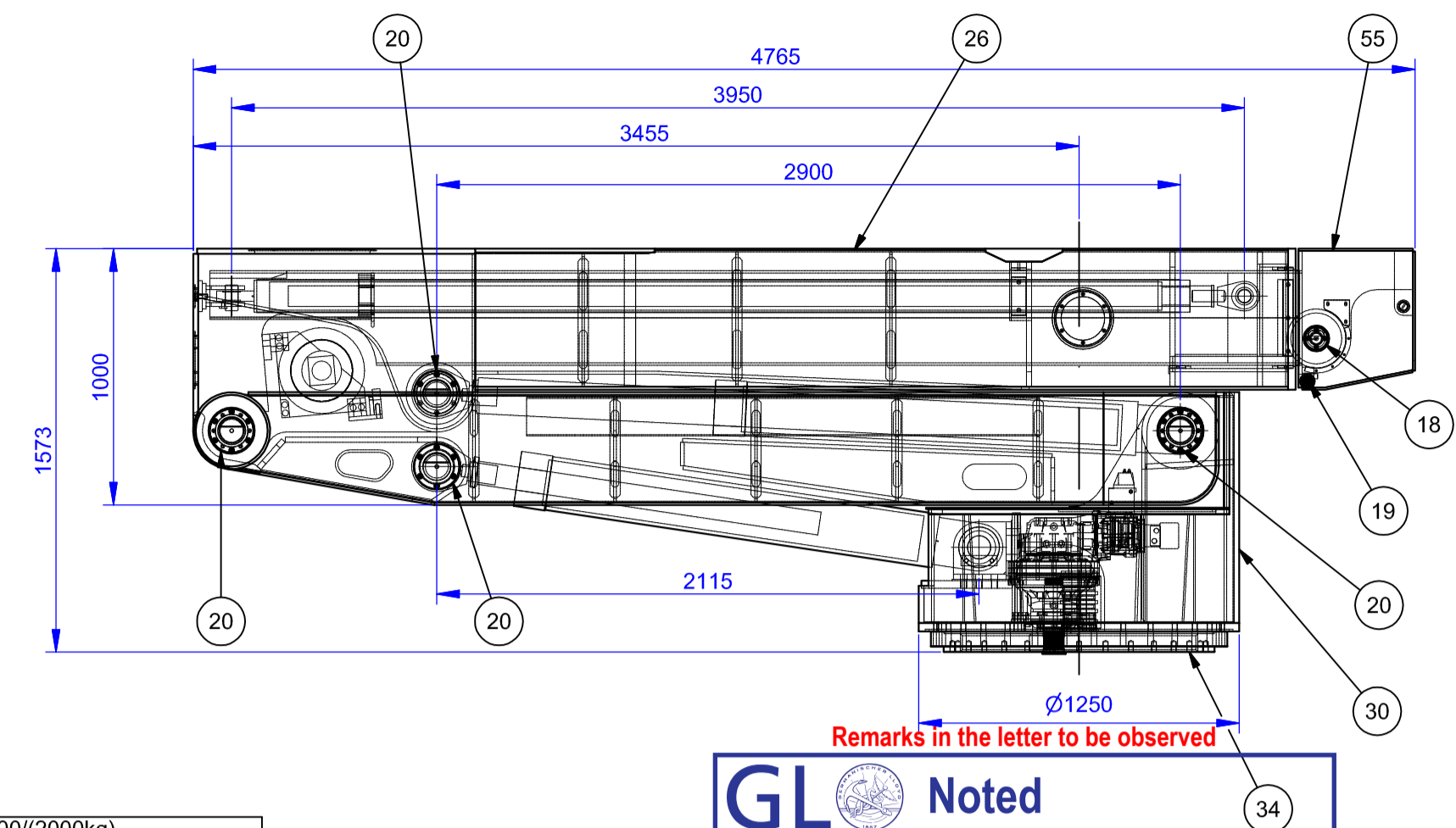

Remarks in the letter to be observed

GL Noted
 s/he
 Hamburg 2013-09-17 Ref.No. 13-056784

Specifications:

SWL (MOB)	3000/(2000kg)
min. reach	3085mm
max. reach	7400mm
max. extending	3100mm
max. heel/trim	57/2° (20°/10° MOB)
dynamic test	3750kg/(2200kg MOB)
220% static test HSL/LSL (MOB only)	(4400kg)
150% winch brake test (MOB only)	(3000kg)
max. hoisting speed (2000kg MOB)	18m/min.
max. lowering speed (2000kg MOB)	36m/min.

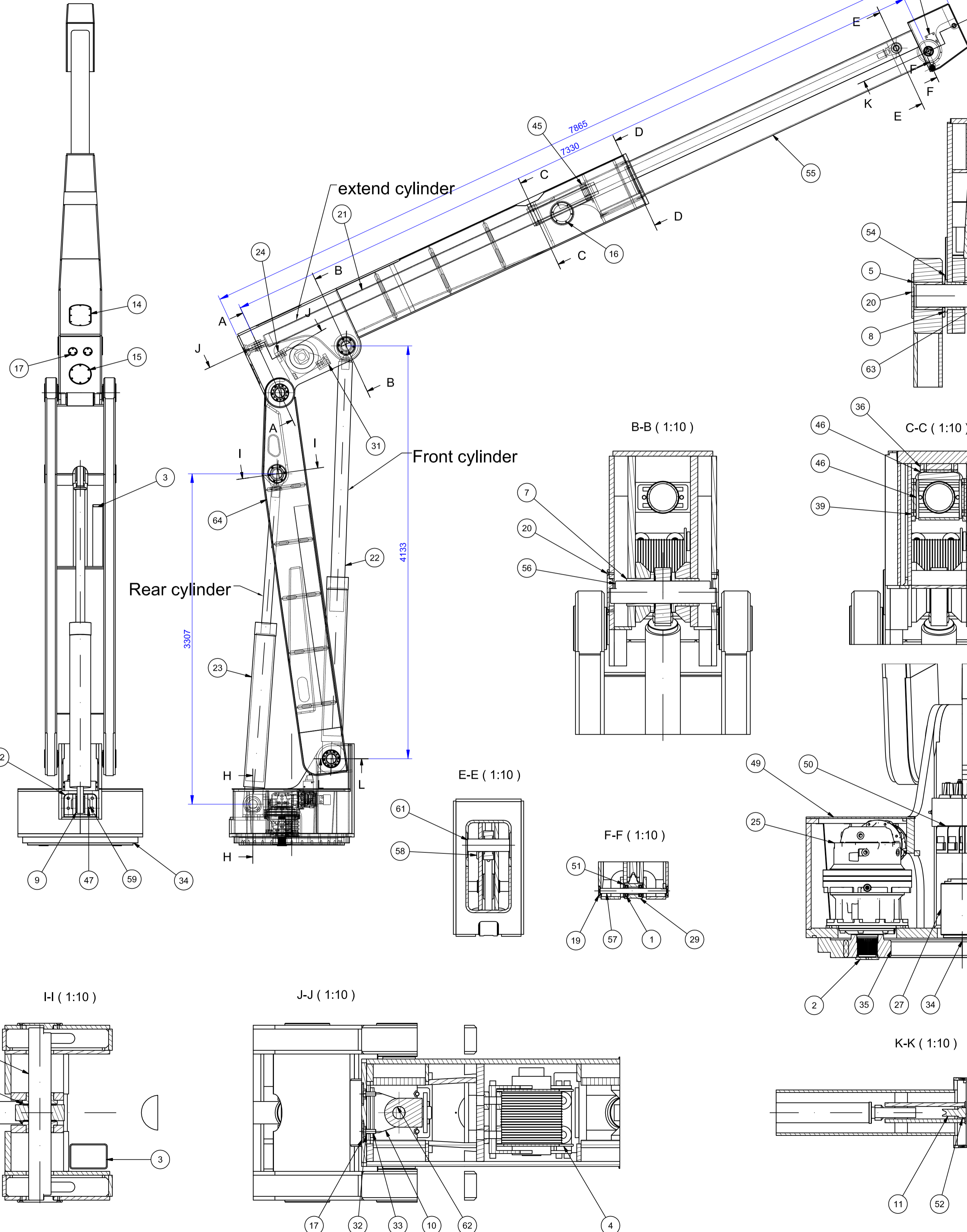

64	folding arm	1				4
63	shaft	3	Ø90x690	SS 1.4057		1a
62	shaft	1	Ø50x100	SS 1.4057		1a
61	shaft	1	Ø50x168	SS 1.4057		1a
60	shaft	1	Ø40x259	SS 1.4057		1a
59	shaft	1	Ø90x185	SS 1.4057		1a
58	shaft	1	Ø40x80	SS 1.4057		1a
57	shaft	1	Ø20x265	SS 1.4057		1a
56	shaft	1	Ø90x420	SS 1.4057		1a
55	ext. beam	1				6
54	ring	4	Ø170x10	SS 1.4404		1a
53	ring	1	Ø50x5	SS 1.4404		1a
52	bearing bush	2	Ø70x24	Orkot		1a
51	ring	2	Ø55x4	Delrin		1a
50	hydraulic	1	pvg 5 fold		Danfoss	
49	coverplate	2		AlMg4,5Mn		1a
48	plate	1	90x30x8	SS 1.4404		1a
47	locking plate	1	140x40x10	SS 1.4404		1a
46	plate	3	150x60x10	Orkot		1a
45	plate	1	165x156x50	Orkot		1a
44	plate	3	150x60x10	Orkot		1a
43	plate	2	300x40x10	Orkot		1a
42	plate	1	330x230x5	Delrin		1a
41	plate	1	330x230x5	Delrin		1a
40	plate	1	100x98x50	Delrin		1a
39	plate	2	150x60x9	AlMg4,5Mn		1a
38	plate	3	150x60x3	AlMg4,5Mn		1a
37	plate	2	300x40x3	AlMg4,5Mn		1a
36	plate	1	150x60x25	AlMg4,5Mn		1a
35	pinion 16t	2	16T mod 10			1b
34	main bearing 92T mod 10	1	062.25.1055.203.41.1523		Rothe erde	
33	m16x40	2	Ø16x40			
32	m16 ring	2	Ø35x3			
31	lierbracket	1				1c
30	column	1				3
29	cabelroll	1	62x70	Bronze LB66		1a
27	hydraulic lead through	1	3 fold		VanDriel	
26	beam	1				5
25	gear	2	ec2090MR		brevini	
24	damper ring	8	Ø70x20	Rubber		1a
23	cylinder rear	1	S=1178 H.O.H=2138, B=180, stang=90		VanDriel	7
22	cylinder front	1	S=1232, H.O.H=2904, B=180, stang=140		VanDriel	7
21	cylinder extend	1	S=3100, H.O.H=3950, B=110, stang=80		VanDriel	7
20	cover plate	8	180x23	SS 1.4404		1a
19	cover plate	2	Ø35x5	SS 1.4404		1a
18	cover plate	2	Ø90x5	SS 1.4404		1a
17	cover plate	2	Ø80x6	SS 1.4404		1a
16	cover plate	1	Ø214x10	AlMg4,5Mn		1a
15	cover plate	1	Ø214x6	AlMg4,5Mn		1a
14	cover plate	1	490x210x6	AlMg4,5Mn		1a
13	clinderbracket	1				1c
12	quiding strip	2	Ø270x17,5x11	SS 1.4404		1a
11	cablewheel	1	Ø230x40	Bronze LB66		1a
10	bracket	1				1c
9	ring	2	Ø158x12	Orkot		1a
8	bearing bush	6	Ø130x75	Orkot		1a
7	bearing bush	2	Ø160x108	Orkot		1a
6	bearing bush	2	Ø140x45	Orkot		1a
5	bearing bush	4	Ø110x115	Orkot		1a
4	MOB tier 1500kg	1	1500 kg		VanDriel	
3	tube	1	2000x150x100	Stainless Steel		
2	Gearbox lockingplate	2	RDF090		Brevini	
1	bearing	2	6204-2rsr			

Parts List

project: 2000kg MOB / 3000kg Folding crane

subject: General assembly

drawn: M de Meij checked: checked client: 2ME proj.nr. se336 client proj.nr. y711

vandriel

date: 15-3-2013 1:25/10 drw. no.: 1 size: A1

Germanischer Lloyd Ref.-No. 13-056784

GLAAG0012153347